

Engineering Data

Model	Damping Range [mm] Step1	Stroke [mm] Step2	Dimensions [mm]				Max. Load Angle [°]	Speed Adjustment Range		Weight (g)
			A	B	C	D		Load Limits [N]	Feed Rate Limits [mm/s]	
ISAA24 - 13B	5	13	174	21		165.4	0.5			415
- 25B	5	25	213	19	26	204.4	1	100~3,000	0.2~30	465
- 51B	5	51	314	16		305.4	0.5			645

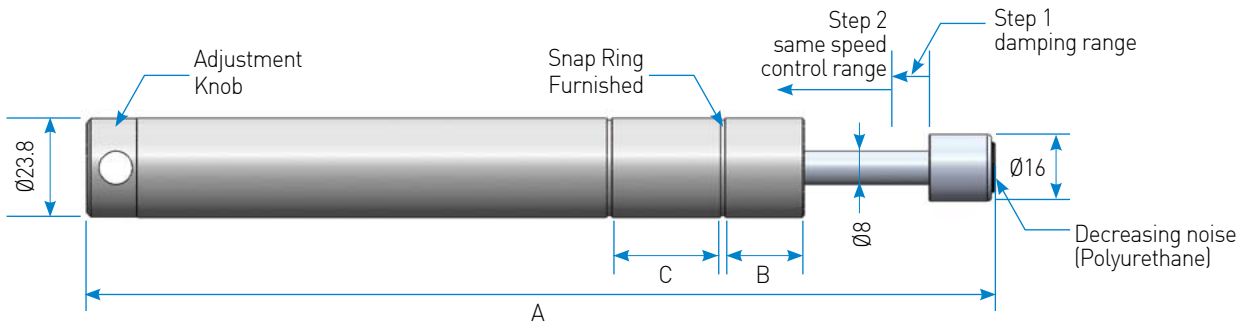

Steel head+Hard PU button
[B TYPE : Black]

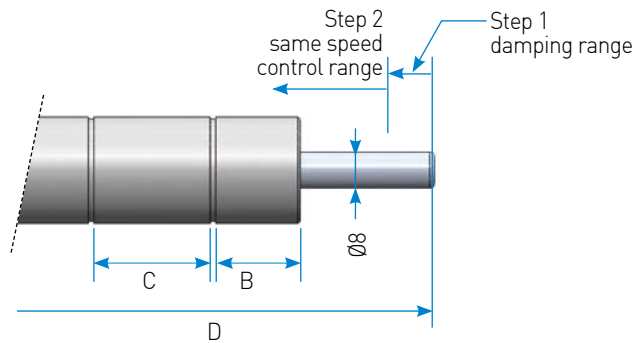

Mount Block

MB 24

